



**1-3.5 ton
ENGINE POWERED
FORKLIFT**

h2000
SERIES **Reliable forklift**

HELI

CHINESE EXPORT BRAND

Recommended
By China Chamber of Commerce for Import and Export of Machinery
And Electric Products



ENGINE POWERED
FORKLIFT

1-3.5 ton

h2000
SERIES

Reliable forklift

A reliable Drive system



As the most reliable transmission system produced by HELI, it has been validated by over twenty years' experience in World market. Meanwhile, various ancillary devices of the power system ensure the reliability effectively.

- ✓ Durable transmission
- ✓ Equipped with the intake system & intake silencer
- ✓ Optional air filter pressure alarm device
- ✓ Automatic engine preheating system
- ✓ Cyclone Air Filter
- ✓ Lost foam casting
- ✓ Various high-power engines are available for customers' optional choices, and the emission meets the latest European & American environmental regulation.

A reliable mast



The high internal-qualified mast confirmedly ensures the safety of the operator, truck and cargo. Standard configuration of the wide-view mast enlarges operators' view effectively, and ensures loading /unloading operations more reliable.

- ✓ Using the best German steel material for triplex mast (option only for triplex mast)
- ✓ The frame of mast has more strength basing on the enlarged channel interface.
- ✓ Clear visibility for standard wide-view mast
- ✓ The channel with own patented technology has the first-rate quality.



A reliable hydraulic system

HELI has the most professional R&D base of cylinders, where we take advantage of the advanced manufacturing technologies and detecting means to ensure the reliability of all cylinders of the hydraulic system.

- ✓ Standard tilt cylinder by HELI
- ✓ Standard lift cylinder by HELI
- ✓ Standard steering cylinder by HELI
- ✓ Self-locking tilt cylinder
- ✓ Standard hydraulic circuit filter
- ✓ Speed buffer device on lifting system



A reliable steering system

The steering system with new technologies not only provides a smoother swerve and faster positioning & steering, but also effectively ensures operators' safety.



- ✓ Wearable tire
- ✓ Smaller turning radius
- ✓ Full hydraulic power steering

Comfortable operation space

Large operation space with ergonomic-design and configuration ensure the operation more comfortable & convenient, and effectively enhance the efficiency & safety of operation.

- ✓ Filled with noise-reducing and buffer rubber material between bonnet and frameworks
- ✓ Newly patented insulation materials of Bonnet
- ✓ Well-designed non-slip mat
- ✓ Special display with easily reading
- ✓ Standard files packet
- ✓ Exhaust system is flexibly connected with the frame.



Manufacturers Data and Design Characteristics

Characteristics		HELI																																														
		CPC10	CPCD10	CPC15	CPCD15	CPC18	CPCD18	CPC20	CPCD20	CPC25	CPCD25	CPC30	CPCD30	CPC35	CPCD35	CPQ10	CPQD10	CPQ15	CPQD15	CPQ18	CPQD18	CPQ20	CPQD20	CPQ25	CPQD25	CPQ30	CPQD30	CPQ35	CPQD35																			
1	Manufacturer																																															
2	Model																																															
3	Power unit	Diesel										Gasoline																																				
4	Rated Capacity	kg	1000	1500	1750	2000	2500	3000	3500	1000	1500	1750	2000	2500	3000	3500																																
5	Load Center	mm	500																																													
6	Operation	Driver seated										Driver seated																																				
Dimensions																																																
7	Overall max. lifting height (with backrest)	h4	mm	4008	4005	4005	3995	3995	4227	4222	4008	4005	4005	3995	3995	4227	4222																															
8	Max. Lifting height	h3	mm	3000																																												
9	Height mast retracted (upright)	h1	mm	1995	1995	1995	2000	2000	2070	2180	1995	1995	1995	2000	2000	2070	2180																															
10	Free lift height	h2	mm	150	155	155	170	170	160	170	150	155	155	170	170	160	170																															
11	Backrest height (from upper face of forks)	h8	mm	1008	1005	1005	995	995	1227	1227	1008	1005	1005	995	995	1227	1227																															
12	Overhead Guard clearance (from face of seat)	h7	mm	1025																																												
13	Overall height (overhead guard)	h6	mm	2070	2070	2070	2070	2070	2090	2090	2070	2070	2070	2070	2070	2090	2090																															
14	Overall length (with forks)	L1	mm	2941	3165	3213	3442	3667	3772	3783	2941	3165	3213	3442	3667	3772	3783																															
15	Overall length (without forks)	L2	mm	2171	2245	2293	2522	2597	2702	2713	2171	2245	2293	2522	2597	2702	2713																															
16	Front overhang	X	mm	421	425	428	482	482	487	498	421	425	428	482	482	487	498																															
17	Rear overhang	L4	mm	350	420	465	440	515	515	515	350	420	465	440	515	515	515																															
18	Wheel base	L5	mm	1400	1400	1400	1600	1600	1700	1700	1400	1400	1400	1600	1600	1700	1700																															
19	Coupler height	h5	mm	250	250	250	290	290	310	310	250	250	250	290	290	310	310																															
20	Min. ground clearance under mast	m1	mm	110	110	110	110	110	135	135	110	110	110	110	110	135	135																															
21	Overall width	B	mm	1070	1070	1070	1150	1150	1225	1225	1070	1070	1070	1150	1150	1225	1225																															
22	Lateral fork adjustment outside of fork (Max./Min.)	S	mm	950/200		1000/222		1000/222		1055/250		1055/250		950/200		1000/222		1000/222		1055/250		1055/250																										
23	Tread (front)	R	mm	890	890	920	970	970	1000	1000	890	890	920	970	970	1000	1000																															
24	Tread (rear)	P	mm	920	920	920	970	970	970	970	920	920	920	970	970	970	970																															
25	Outside turning radius	Wa	mm	1880	1955	1985	2170	2240	2400	2420	1880	1955	1985	2170	2240	2400	2420																															
26	Inside turning radius	V	mm	110	110	95	160	160	200	200	110	110	95	160	160	200	200																															
27	Min. intersecting aisle	Ra	mm	1977	2052	2093	2200	2280	2380	2400	1977	2052	2093	2200	2280	2380	2400																															
28	Tilting angles (forward/backward)	α/β	6° / 12°																																													
29	Fork dimensions (axbxc)	mm	770×100×32	920×100×35	920×100×35	920×100×45	1070×100×45	1070×125×45	1070×125×45	1070×125×50	770×100×32	920×100×35	920×100×35	920×100×45	1070×100×45	1070×125×45	1070×125×50																															
Performance																																																
30	Max. Traveling speeds (With/Without load)	km/h	13.5/14.5		17/19		18/19		19/19		13.5/14.5		17/19		18/19		19/19																															
31	Lifting Speeds (With/Without load)	mm/s	590/650		530/550		440/480		330/370		590/650		530/550		450/480		310/340																															
32	Lowering Speeds (With/Without load)	mm/s	450/550		450/550		450/500		350/400		450/550		450/550		450/500		350/400																															
33	Max. Draw-bar pull (With/Without load)	kN	12.3/7	18/7	12.3/7	18/7	12.3/7	18/7	14.2/9	16.4/9	13.7/8.6	16.2/8.6	13.5/9.8	16/9.8	16.7/11.8	20.6/11.8	9.3/6.9	14.2/6.9	9.3/6.9	14.2/6.9	9.3/6.9	14.2/6.9	11/9	12.3/9	9.8/8.6	12.3/8.6	9.1/9.8	10.8/9.8	14/9.8	18.5/9.8																		
34	Max. Negotiable Gradient (With/Without load)	%	≥20		23/20		25/20		20/17		21.5/17		15/17		16/17		20/15		22/15		30/22		37/22		23/18		27/18		20/17		24/17		18/20		18/20		15/17		15/17		12/14		14/14		15/15		15/15	
Weights																																																
35	Service Mass	kg	2220	2660	2890	3320	3680	4270	4700	2220	2660	2890	3320	3680	4270	4700																																
36	Load Wheel with load (Front/Rear)	kg	2830/390	3640/520	4040/600	4788/532	5562/618	6543/727	7380/820	2830/390	3640/520	4040/600	4788/532	5562/618	6543/727	7380/820																																
37	Load Wheel without load (Front/Rear)	kg	1220/1000	1170/1490	1140/1750	1328/1992	1472/2208	1708/2562	1880/2820	1220/1000	1170/1490	1140/1750	1328/1992	1472/2208	1708/2562	1880/2820																																
Tyres																																																
38	Wheels number front/rear (x=driven)	2X/2				2X/2				2X/2				2X/2				2X/2																														
39	Tyre Type	Pneumatic				Pneumatic				Pneumatic				Pneumatic				Pneumatic																														
40	Tyre size (front)	6.50-10-10PR				7.00-12-12PR				28×9-15-12PR				28×9-15-14PR				6.50-10-10PR				7.00-12-12PR				28×9-15-12PR				28×9-15-14PR																		
41	Tyre size (rear)	5.00-8-8PR				6.00-9-10PR				6.50-10-10PR				6.50-10-10PR				5.00-8-8PR				6.00-9-10PR				6.50-10-10PR				6.50-10-10PR																		
42	Service Brake	Hydraulic-Foot Pedal										Hydraulic-Foot Pedal																																				
43	Parking Brake	Mechanical-Hand Lever										Mechanical-Hand Lever																																				
Drive																																																
44	Battery (Voltage/Capacity)	V/Ah	12/80				12/80				12/60				12/60																																	
45	Internal Combustion Engine Model	Kubota V2403				Kubota V2403				Kubota V3600				NISSAN K15				NISSAN K21				NISSAN K25																										
46	Internal Combustion Engine Rated Output	kW/rpm	35.4/2400				35.4/2400				36.5/2600				46.9/2400				23.6/2400				31.2/2250				37.6/2400																					
47	Internal Combustion Engine Rated Torque	Nm/rpm	161.3/1600				161.3/1600				164/1500				210/1600				103/1600				143.7/1600				176.5/1600																					
48	Internal Combustion Engine Number of Cylinder	4-87×102.4				4-87×102.4				4-98×120				4-75.5×83				4-89×83				4-89×100																										
49	Internal Combustion Engine Displacement	L	2.434				2.434				3.62				1.468				2.065				2.488																									
50	Internal Combustion Engine Fuel Tank Capacity	L	38				60				38				60																																	
51	Transmission Number of Speed Fwd/Bwd type	1-1Power Shift T/M, 2-2 Manual Shift T/M				1-1Power Shift T/M, 2-2 Manual Shift T/M				1-1Power Shift T/M, 2-2 Manual Shift T/M				1-1Power Shift T/M, 2-2 Manual Shift T/M																																		

Reliable special designed instrument

The reliable special instrument gives a complete display of the vital information, like operation status, fault detection, etc. It ensures the operator predominate the vehicle status more intuitive and convenient.

- ✓ Stepping motor core
- ✓ Programmable LCD
- ✓ Electrical safety standard meets CE requirements

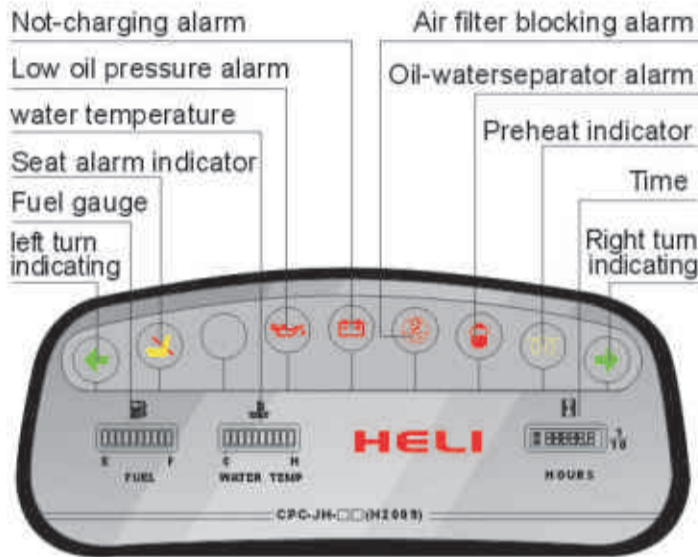

Standard

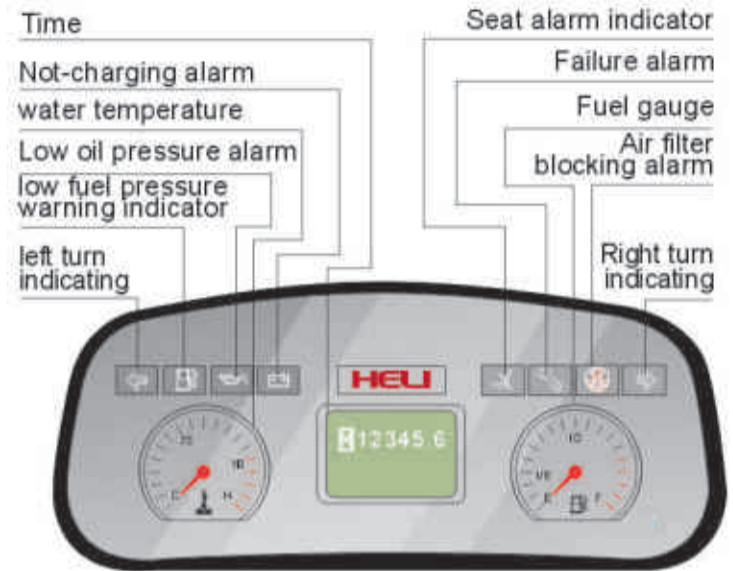

With PSI motor

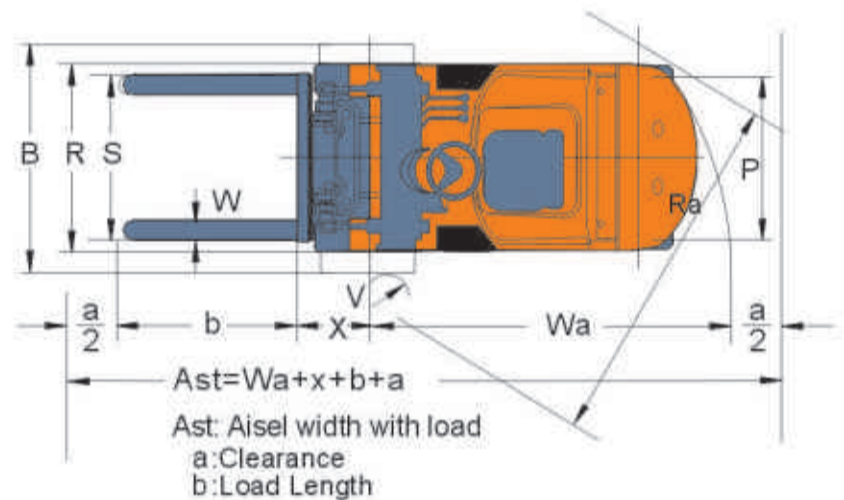
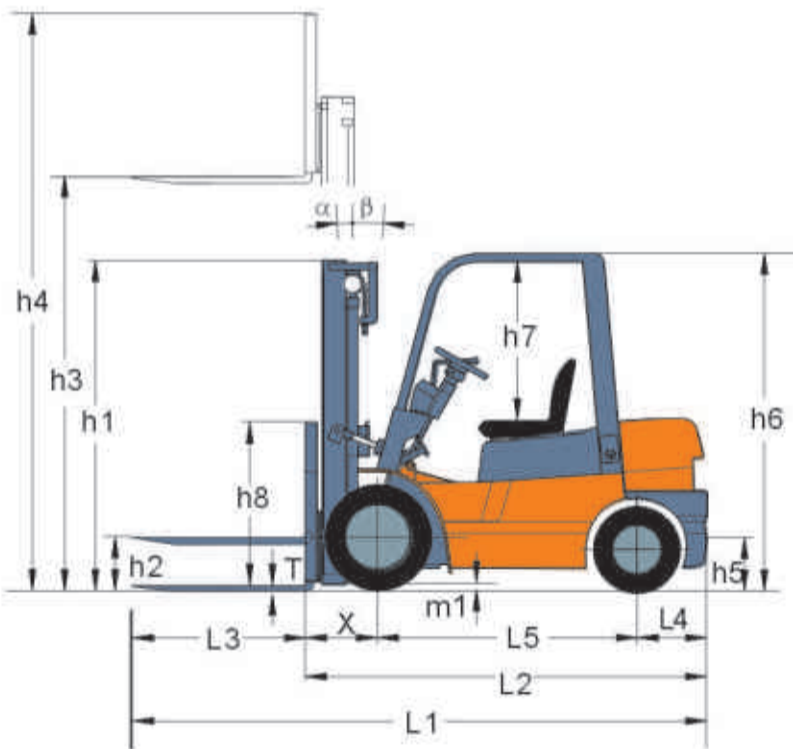

GROUND CLEARANCE	2t/2.5t	3t
Drive Axle	135	140
Steer Axle	150	150
Counter Weight	140	155
Frame	120	130

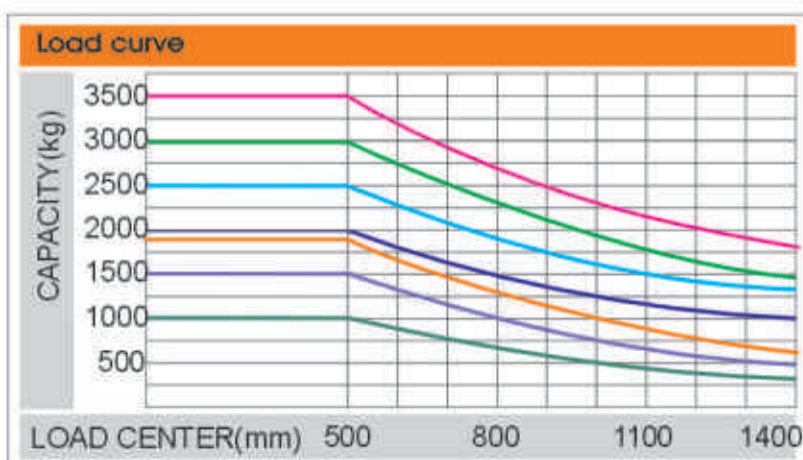

- CPC20/CPD20
CPQD20/CP(Q)YD20
- CPC25/CPD25
CPQD25/CP(Q)YD25
- CPC30/CPD30
CPQD30/CP(Q)YD30
- CPC35/CPD35
CPQD35/CP(Q)YD35
- CPC18/CPD18
CPQ18/CPQD18
- CPC15/CPD15
CPQ15/CPQD15
- CPC10/CPD10
CPQ10/CPQD10

Note:
Capacities shown are computed with upright in vertical position, based on a 1000 mm cube load configuration with the center of gravity at the true center of the cube, and standard forks. Truck capacities with upright in forward tilt position will be less. Long forks, and unusually wide or loads may also reduce capacity.

Reliable forklift

1-3.5t WIDE VIEW MAST

Mast model	Max. fork height mm	Capacity at 500mm, Load center (kg)								Overall Mast Height (mm)				Tilting Angle	Service Weight (kg)							
		CPQ10/ CPC10/ CPCD10	CPQ15/ CPC15/ CPCD15	CPQ18/ CPC18/ CPCD18	CPQ20/ CPC20/ CPCD20	CPQ25/ CPC25/ CPCD25	CPQ30/ CPC30/ CPCD30	CPQ35/ CPC35/ CPCD35	1-1.8t	2-2.5t	3t	3.5t	CPQ10/ CPC10/ CPCD10		CPQ15/ CPC15/ CPCD15	CPQ18/ CPC18/ CPCD18	CPQ20/ CPC20/ CPCD20	CPQ25/ CPC25/ CPCD25	CPQ30/ CPC30/ CPCD30	CPQ35/ CPC35/ CPCD35		
M200	2000	1000	1500	1750	2000	2500	3000	3500	1495	1500	1555	1680	6-12	2120	2530	2760	3240	3600	4265	4800		
M250	2500	1000	1500	1750	2000	2500	3000	3500	1745	1750	1815	1930	6-12	2145	2555	2785	3280	3640	4310	4850		
M300	3000	1000	1500	1750	2000	2500	3000	3500	1995	2000	2070	2180	6-12	2220	2660	2890	3320	3680	4270	4700		
M330	3300	1000	1500	1750	2000	2500	3000	3500	2145	2155	2215	2330	6-12	2195	2605	2835	3345	3705	4375	4935		
M350	3500	1000	1500	1750	2000	2500	3000	3500	2245	2255	2315	2430	6-12	2210	2620	2850	3360	3720	4390	4935		
M370	3700	1000	1500	1750	2000	2500	3000	3500	2345	2355	2415	2530	6-6 6-12	2230	2640	2870	3375	3735	4410	4970		
M400	4000	1000	1500	1700 *1750	2000	2500	3000	3200 *3500	2545	2555	2615	2730	6-6 6-12	2270	2680	2910	3420	3780	4470	5055		
M425	4250	950	1400 *1500	1600 *1750	1900 *2000	2250 *2500	2850 *3000	3100 *3200	2670	2675	2740	2855	6-6 6-12	2285	2695	2925	3440	3800	4490	5085		
M450	4500	950	1300 *1400	1550 *1700	1800 *1900	2150 *2400	2750 *3000	3000 *3050	2795	2800	2865	2980	6-6 6-12	2300	2710	2940	3460	3820	4510	5100		
M500	5000	930 *950	1000 *1350	1100 *1600	1600 *1700	1650 *2200	2400 *2650	2500 *2850	3045	3050	3115	3230	6-6 6-12	2335	2745	2975	3500	3860	4560	5170		
M550	5500	*900	*1150	*1500	*1600	*1950	*2400	*2500	3345	3350	3415	3530	*3-6	2500	2910	3140	3695	4055	4780	5270		
M600	6000	*850	*1050	*1400	*1500	*1800	*2200	*2300	3595	3600	3665	3780	*3-6	2530	2940	3170	3735	4095	4820	5330		

NOTE: (1)For gas,diesel model :+90kg,dual wheels weight +110kg.
 (2)*(Front wheel) is dual wheels load capacity.
 (3)Rated capacity with(*) shows capacity with front dual tires.
 (4)Max lifting without lift-bracket:-470mm.

1-3.5t WIDE VIEW FULL FREE 2-STAGE MAST

Mast model	Max. fork height mm	Capacity at 500mm, Load center (kg)								Overall Mast Height (mm) At Lowered				Free Lift (with Backrest)				Tilting Angle	Service Weight (kg)							
		CPQ10/ CPC10/ CPCD10	CPQ15/ CPC15/ CPCD15	CPQ18/ CPC18/ CPCD18	CPQ20/ CPC20/ CPCD20	CPQ25/ CPC25/ CPCD25	CPQ30/ CPC30/ CPCD30	CPQ35/ CPC35/ CPCD35	1-1.8t	2-2.5t	3t	3.5t	1-1.8t	2-2.5t	3t	3.5t	CPQ10/ CPC10/ CPCD10		CPQ15/ CPC15/ CPCD15	CPQ18/ CPC18/ CPCD18	CPQ20/ CPC20/ CPCD20	CPQ25/ CPC25/ CPCD25	CPQ30/ CPC30/ CPCD30	CPQ35/ CPC35/ CPCD35		
ZM200	2000	1000	1500	1750	2000	2500	3000	3500	1535	1495	1570	1680	490	495	350	560	6-12	2135	2555	2795	3250	3615	4290	4830		
ZM250	2500	1000	1500	1750	2000	2500	3000	3500	1745	1745	1820	1930	735	745	600	710	6-12	2195	2615	2855	3340	3680	4360	4880		
ZM300	3000	1000	1500	1750	2000	2500	3000	3500	1995	1995	2070	2180	985	995	850	960	6-12	2230	2650	2890	3385	3725	4390	4930		
ZM330	3300	1000	1500	1750	2000	2500	3000	3500	2145	2145	2220	2330	1135	1145	1000	1100	6-12	2250	2670	2910	3405	3750	4415	4965		
ZM350	3500	1000	1500	1750	2000	2500	3000	3500	2245	2245	2320	2430	1235	1245	1100	1210	6-12	2265	2685	2925	3420	3765	4460	5000		
ZM370	3700	1000	1500	1750	2000	2500	3000	3500	2370	2370	2420	2530	1360	1370	1215	1335	6-6 6-12	2280	2700	2940	3375	3735	4410	5000		
ZM400	4000	1000	1500	1700 *1750	2000	2500	3000	3200 *3500	2545	2545	2620	2730	1535	1545	1400	1510	6-6 6-12	2330	2750	2990	3500	3840	4545	5085		
ZM425	4250	950	1400 *1500	1600 *1750	1900 *2000	2250 *2500	2850 *3000	3100 *3200	2670	2670	2745	2855	1660	1670	1525	1635	6-6 6-12	2350	2770	3010	3525	3865	4565	5115		
ZM450	4500	950	1300 *1400	1550 *1700	1800 *1900	2150 *2400	2750 *3000	3000 *3050	2795	2795	2870	2980	1785	1795	1650	1760	6-6 6-12	2365	2785	3025	3545	3880	4595	5130		
ZM500	5000	930 *950	1000 *1350	1100 *1600	1600 *1700	1650 *2200	2400 *2650	2500 *2850	3045	3045	3120	3230	2035	2045	1920	2010	6-6 6-12	2400	2820	3060	3590	3925	4615	5200		
ZM550	5500	*900	*1150	*1500	*1600	*1950	*2450	*2500	3345	3345	3420	3530	2335	2345	2200	2310	*3-6	2575	2995	3235	3790	4120	4875	5300		
ZM600	6000	*850	*1050	*1400	*1500	*1800	*2200	*2300	3595	3595	3670	3780	2585	2595	2450	2560	*3-6	2610	3030	3270	3835	4170	4920	5360		

NOTE: (1)2-2.5t free lift height (without backrest):+435mm,3t free lift height (without backrest):+580mm.
 (2)Dual wheels weight:+110kg.
 (3)*(front wheel) is dual wheels load capacity.
 (4)Max lifting height without bracket:-470mm.
 (5)Free lifting height without bracket:+470mm.
 (6)Rated capacity with(*) shows capacity with front dual tires.

1-3.5t WIDE VIEW FULL FREE 3-STAGE MAST

Mast model	Max. fork height mm	Capacity at 500mm, Load center (kg)								Overall Mast Height (mm) At Lowered				Free Lift (with Backrest)				Tilting Angle	Service Weight (kg)							
		CPQ10/ CPC10/ CPCD10	CPQ15/ CPC15/ CPCD15	CPQ18/ CPC18/ CPCD18	CPQ20/ CPC20/ CPCD20	CPQ25/ CPC25/ CPCD25	CPQ30/ CPC30/ CPCD30	CPQ35/ CPC35/ CPCD35	1-1.8t	2-2.5t	3t	3.5t	1-1.8t	2-2.5t	3t	3.5t	CPQ10/ CPC10/ CPCD10		CPQ15/ CPC15/ CPCD15	CPQ18/ CPC18/ CPCD18	CPQ20/ CPC20/ CPCD20	CPQ25/ CPC25/ CPCD25	CPQ30/ CPC30/ CPCD30	CPQ35/ CPC35/ CPCD35		
ZSM360	3600	1000	1450	1750	2000	2400	2900	3300	1790	1795	1946	1985	750	755	670	710	6-6 6-12	2275	2695	2935	3470	3810	4580	-		
ZSM400	4000	1000	1400	1600	1900	2400	2900	3300	1920	1920	2065	2115	880	880	795	845	6-6 6-12	2300	2720	2960	3505	3845	4615	-		
ZSM430	4350	900 *950	1350 *1400	1550 *1700	1850 *1900	2200 *2400	2800 *2900	3000 *3000	2040	2045	2190	2240	1000	1005	920	970	6-6 6-12	2325	2745	2985	3535	3885	4650	5075		
ZSM450	4500	900 *950	1300 *1350	1500 *1650	1750 *1800	2150 *2300	2700 *2800	2900 *2900	2090	2095	2240	2340	1050	1050	970	1070	6-6 6-12	2355	2750	2995	3565	3910	4660	5080		
ZSM470	4700	900 *930	1300 *1350	1450 *1600	1720 *1800	2000 *2300	2600 *2800	-	2160	2160	2240	-	1120	1120	970	-	6-6 6-12	2365	2760	3005	3565	3910	4660	-		
ZSM480	4800	900 *920	1100 *1350	1400 *1580	1700 *1800	1950 *2300	2500 *2800	2600 *2900	2190	2195	2340	2440	1150	1155	1070	1170	6-6 6-12	2375	2775	3010	3575	3915	4680	5095		
ZSM500	5000	900 *900	1100 *1300	1150 *1550	1600 *1750	1650 *2250	2400 *2750	2450 *2850	2290	2295	2440	2565	1250	1255	1170	1295	6-6 6-12	2400	2780	3035	3715	4055	4725	5085		
ZSM540	5400	800 *900	850 *1250	850 *1500	1450 *1700	1500 *2150	2250 *2650	2300 *2700	2420	2420	2565	2665	1380	1380	1295	1395	3-6 6-12	2420	2815	3055	3895	4235	4760	-		
ZSM600	6000	550 *850	550 *1100	550 *1400	950 *1600	1000 *1800	1500 *2100	1650 *2200	2650	2645	2790	2885	1610	1605	1520	1615	3-6 6-12	2480	2875	3115	3945	4285	4850	-		
ZSM650	6500	*800	*1000	*1250					2855				1815				*3-6	2530	2925	3165				-		
ZSM700	7000	-	-	*850	*1000	*1200	*1500	-	3025	3031	3176	-	1985	1990	1906	-	*3-6	2580	2975	3215	4345	4485	5250	-		

NOTE: (1)2-2.5t free lift height (without backrest):+435mm,3t free lift height (without backrest):+580mm.
 (2)Dual wheels weight:+110kg.
 (3)*(front wheel) is dual wheels load capacity.
 (4)Max lifting height without bracket:-470mm.
 (5)Free lifting height without bracket:+470mm.
 (6)Rated capacity with(*) shows capacity with front dual tires.

HELI

h2000 SERIES

Reliable forklift



1-3.5 ton ENGINE POWERED FORKLIFT

STANDARD EQUIPMENT

Hour meter	Overhead guard
Horn	Standard forks
Oil pressure alarm	Central Control Box
Three-spool control valve	Hydraulic circuit oil filter
Power steering	Radiator tank
Rubber pedal pad	Speed-limiting valve
Backrest	Oil meter
Back view mirror	Battery-charge indicator
Front combined lights	Wide-view mast
Transmission oil filter	Intake device
Engine flameout device	Durable tire
Parking brake cable	Operating handles
Water temperature meter	Traction pin
Attached tools	Standard seat
Rear combined lights	Hudraulic oil gauge
Reversing buzzer	Overhead guard raincoat
Self-locking tilt valve	Torque converter oil gauge
Tilt adjustable steering column	Combined display

OPTIONS

Cab	Tilt cylinder sleeve
Rotating warning light	Steering cylinder sleeve
Vertical exhaust	User-specified color
Double air filter	Optional attachments
Suspension seat	Steel protective fences
Extended fork sleeve	Dual tires and protective devices
Heater	LPG with the flip seat
Solid tire	LPG single and dual-fuel system
Widening fork carriage	Power brake
Windglass	Side shifter
Purifying muffler	
Fire muffler	
Fire extinguisher	
Rear lights	
Air conditioning (some models)	
Electro-hydraulic switch	
OPS driving control	
Torque converter oil temperature meter	

ANHUI HELI CO., LTD.

ADDR 15 WEST WANGJIANG ROAD, HEFEI, ANHUI, P.R. CHINA

TEL (86 551)3639068,3639258,3639358

FAX (86 551)3639966

WEBSITE <http://www.helichina.com>

* Details of specifications and equipment are based on information available at the time of printing and may change without notice.



TOP1 FORKLIFT MANUFACTURING AND SALE
IN CHINA CONTINUOUSLY FOR 20 YEARS

AUTHORIZED DEALER