

HELI

CBD20-410 Electric Pallet Truck

Configuration and performance

- Mechanical Steering-Economic, comfortable, more reliable.
- AC Driving System-Low noise, quiet, without carbon brush and free maintenance.
- Electric Lifting-Rapid, efficient, electricity limit switch is Standard.
- Excellent Design-Easily in and out of the double tray.
- Energy conservation-Save energy, more environmentally friendly.
- AC Controller-Stepless, strong power, multiple automatic protection.

Option

- Lithium battery

Economical



AC | Electronic limiter

Fork suitable for reversible pallet

CBD20-410

Feature			
Model		CBD20	
Configuration No.		410	
Loading capacity	kg	2000	
Load center	mm	600	
Wheel base	mm	1407	
Operating type		Pedestrian / Ride On	
Wheels			
Wheels type		PU	
Wheel quantity Driving wheel/Balance wheel/Bearing wheel		1/1/4	
Driving wheel size	mm	∅248×75	
Bearing wheel size	mm	∅84×80(Double wheels)	
Balance wheel size	mm	∅115×55	
Dimension			
Min.fork lowered height	mm	85	
Max.fork lifting height	mm	195	
Max.lifting height	mm	110	
Overall fork width	mm	550/600/650/685	
Inside width between forks	mm	210/260/310/345	
Fork length	mm	1150/1200	
Fork width	mm	170	
Fork thickness	mm	75	
Overall length	mm	1874/2247	
Overall width	mm	725	
Overall height(With handle)	mm	1475	
Overall height(Without handle)	mm	940	
Min.Turning radius	mm	1680/2060	
Min.Aisle width for pallets 800×1200	mm	2000/2320	
Min.Aisle width for pallets 1000×1200	mm	2030/2340	
Performance			
Travel speed,laden/unladen	km/h	5.5/6.0	
Lift speed,laden/unladen	mm/s	30/35	
Lowering speed,laden/unladen	mm/s	40/35	
Gradeability,laden/unladen	%	6/16	
Electrical configuration			
Drive motor	kW	AC 1.5	
Lift motor	kW	DC 1.2	
Steering motor	kW	-	
Brake		Electromagnetic/Regenerative	
Battery		Lead-acid battery	
Battery voltage / capacity	V/Ah	24/210	Lithium battery (Optional) 24/200
Controller		ZAPI	ZAPI
Battery weight	kg	192	96
Service weight with battery	kg	664	544

* Details of specifications and equipment are based on information available at time of printing and may change without notice.

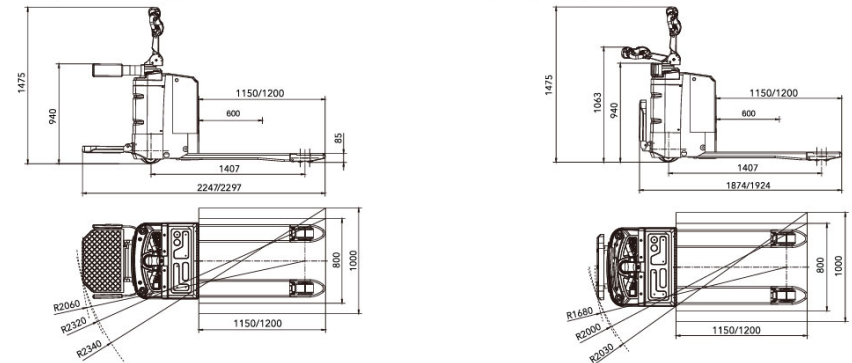

ANHUI HELI CO., LTD.

ADD: NO.668 Fangxing Street,Economical Development Zone,Hefei,PR.China
 TEL: (86 551)63639068 (America) 63639258 (Europe) 63639358 (Asia)
 63662105 (Africa & Middle East) 63639530 (Key Accounts division)
 63662105 (Wheel loader)
 FAX: (86 551)63639966
 WEBSITE: <http://www.heliforklift.net>
 Email: hel@helichina.net

AUTHORIZED DEALER